

## B8 Suspension, Touring

### Touring Suspension Kit

#### Application Guide

Qty	Description	Part Number
	A5/S5 Performance Spring Kit	SP04.0004.00
	A4/S4 Performance Spring Kit	SP04.0005.00

#### Special Tools Required

Qty	Description	Part Number
1	Torque Wrench	VAG 1331
1	Torque Wrench	VAG 1332
1	Engine/transmission jack	VAG 1383 A
1	Spring Compressor	VAG 1752/1
1	Spring holder	VAG 1752/7
1	Rear Spring Compressor	VAS 6274
1	Supplementary Set	VAS 6274/10
1	Hollow Piston Cylinder	VAS 6179
1	Spreader	3424
1	Tensioning strap	T10038

Please read ALL instructions prior to attempting installation. Please torque all fasteners to specifications.

## Front Removal and Install

1	<p>Before removing any parts, park the car on a secure, stable, and level surface. Remove wheel trim; pull trim cap off light-alloy wheels (using puller in vehicle tool kit) and loosen (but do not remove) the wheel lug nuts. Jack the vehicle up, and place the car on four stable jack stands or use a professional vehicle lift. We recommend having two people available for certain steps of the installation.</p>
2	Remove wheels
3	Before removing left suspension strut, remove headlight range control link from track control link.
4	<p>Remove the fastener and plastic nut on the inside of the fender lip.</p> <p>This is to provide additional clearance for the tires. The clip will not be reinstalated.</p>
5	<p>Remove pinch bolt for upper control arms. Remove both joint pins in upper control arms from wheel bearing housing. The slits in wheel bearing housing must not be widened using a chisel or similar tool!</p>

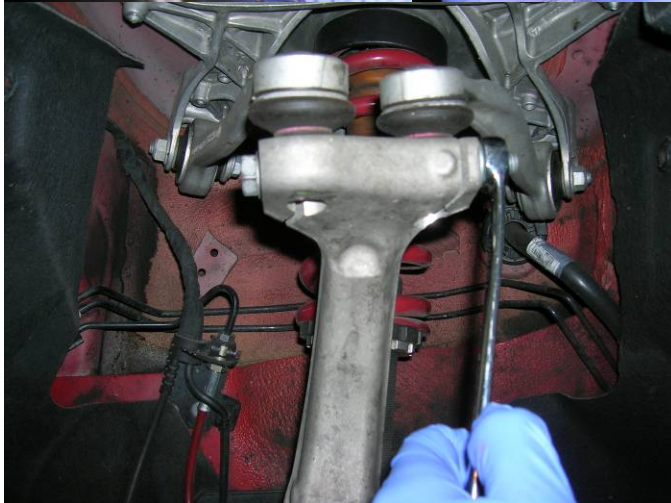

6 Disconnect the bolt that connects the swaybar link to the damper fork. Bolt can remain on swaybar link.



7 Remove bolts that connect damper fork to lower link and damper. Use spreader (Audi Tool # 3424 or equivalent) to remove fork from damper. Pull bearing housing down to gain enough clearance to remove fork.

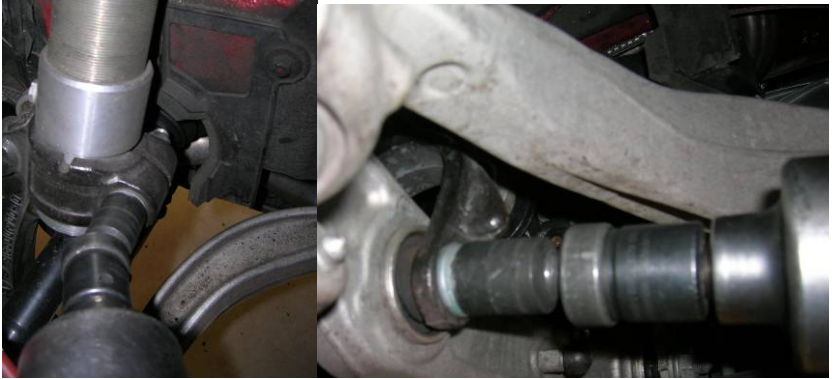

8 Perform these steps on both sides of the car and then open the front hood to reach the bolts that hold the upper mount.

9 Unclip plenum chamber covers-1 & 3 - and remove them.

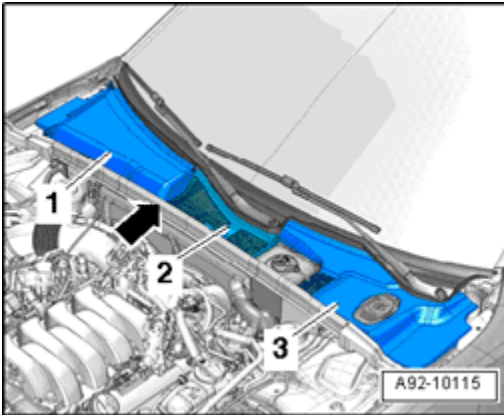

10 Remove nut - **1** - . Remove filler neck - **3** - with filler tube from washer fluid reservoir and body opening - **arrow B** - .

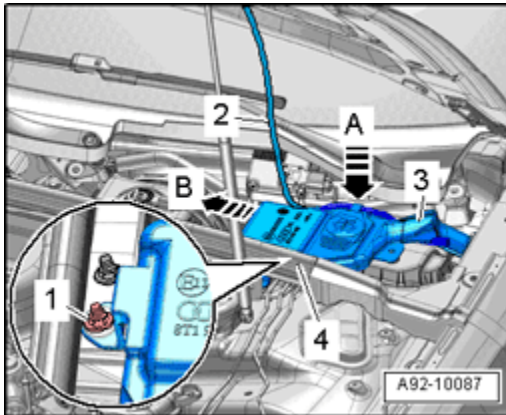

11 Remove nuts - **arrows** - , move coolant reservoir upward and lay it aside to access the mounting bolt.

Do not disconnect any coolant lines, reservoir does not have to be removed.

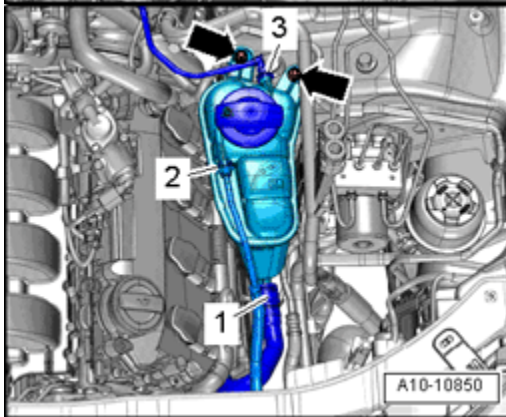

12 Remove bolts - **arrows** - and remove suspension strut with the mounting bracket.

Remove similar bolts from passenger side and remove passenger side suspension strut with the mounting bracket.

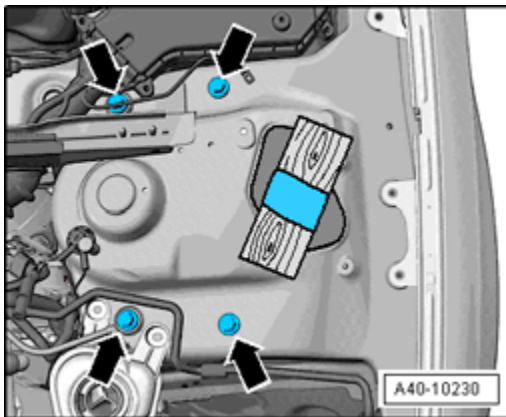

13 Remove OEM damper and spring from upper mount.

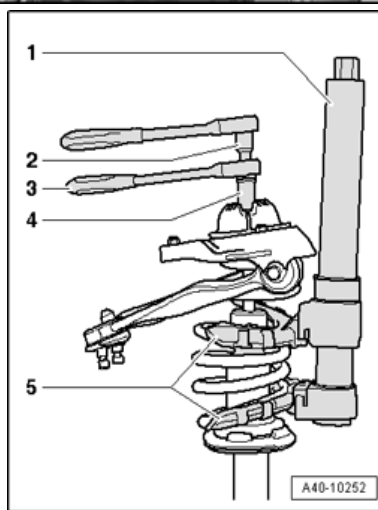



14	<p>Remove OEM bumpstop and trim the large end of the bumpstop to achieve an overall length of –</p> <p><b>2 ¾ inch</b></p> <p><b>Note – If bumpstop is within this length (+/- ¼”) no trimming is needed. Audi has changed recent vehicles to a new bumpstop which works with our application.</b></p>
15	<p>Reinstall bumpstop and replace the OEM spring with the Stasis supplied spring.</p> <p><b>*Note*</b>- Bumpstop will no longer capture on the damper shaft and will sit on the damper body.</p>
16	<p>Reassemble damper assembly to the upper mount and reinstall complete assembly. Installation is the reverse of the removal steps.</p> <p><b>*Note*</b>- Bonded rubber suspension bushings can only be turned to a limited extent. <u>All mounting bolts of the suspension links must only be tightened when the suspension is compressed to the curb weight position.</u></p>



## Rear Removal and Installation

1	Remove wheel
2	<p>Remove cover over lower damper bolt, then remove lower damper bolt (21 mm).</p> <p>Remove the two fender liner clips one either side of the damper (#2) by gently prying upwards on the open end of the clips.</p> <p>Pushing the fender liner out of the way, remove upper damper bolts (#1 16 mm) and remove the damper by dropping straight down through the opening in the lower control arm.</p>

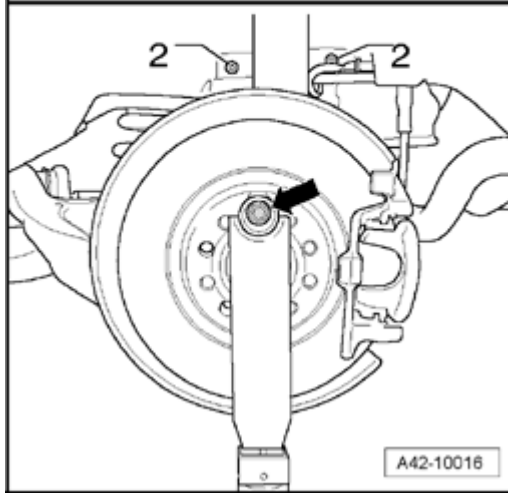
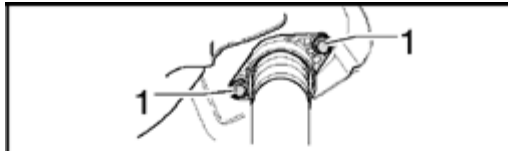
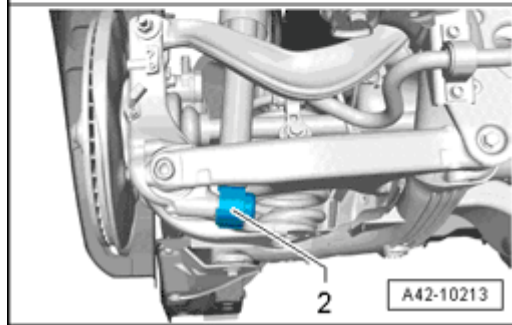
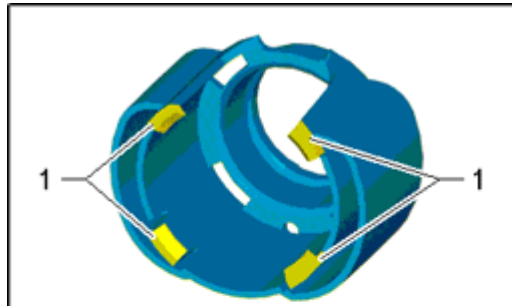

3 Remove upper mount from damper and set aside.

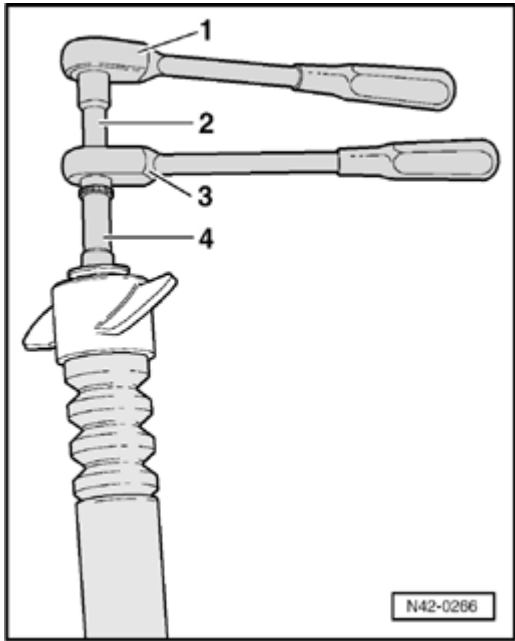

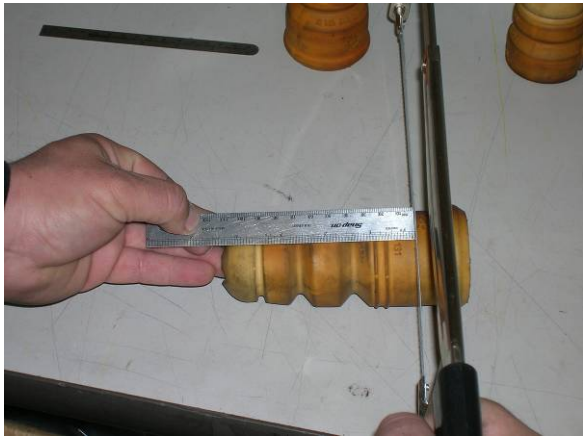

4 Remove OEM bumpstop and trim the large end of the bumpstop to achieve an overall length of –  
**4 3/8 inch**  
**Note – If bumpstop is within this length (+/- 1/4”) no trimming is needed. Audi has changed recent vehicles to a new bumpstop which works with our application.**  
Reassemble damper.

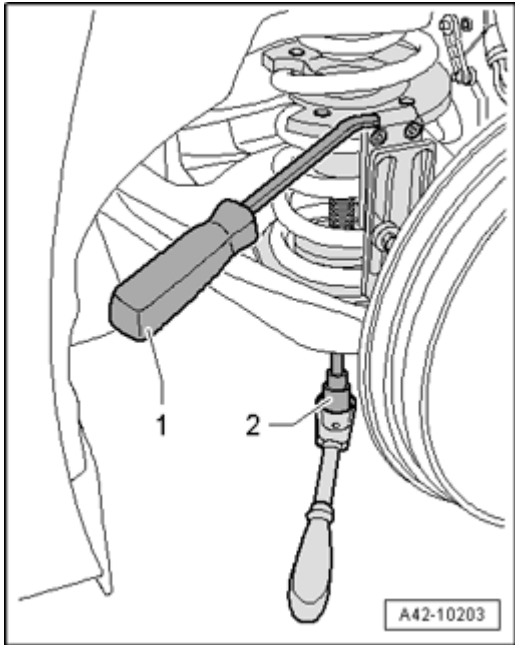

5 Remove rear coil springs with spring compressor tool VAS 6274 and VAS 6274/10.



6	<p>Install STaSIS rear spring with the spring compressor. Progressive coils towards the top.</p>	
7	<p>Install damper assembly and torque to:</p> <p>Upper bolt: 37 ft-lbs</p> <p>Lower bolt: 111 ft-lb</p> <p>Note –</p> <p>Bonded rubber suspension bushings can only be turned to a limited extent. <u>The mounting bolts of the suspension links must only be tightened when the suspension is compressed to the curb weight position.</u></p>	
8	<p>Install wheels and tighten. Lower the car onto its wheels and torque all wheel lug bolts to the recommended torque.</p> <p><b>Note:</b> Check wheel alignment after suspension installation</p>	